

# *veritas*<sup>®</sup>

## Bevel-Up Planes



U.S. Pat. No. 7,603,783

Veritas® bevel-up planes are versatile, easy to use woodworking planes. The bevel-up configuration lets you vary the cutting angle as needed by altering the blade bevel angle. A low cutting angle of 37° (12° bed with 25° blade) minimizes fiber tearing in end grain. Higher cutting angles (e.g., 50° resulting from a 38° blade) are suited to smoothing. The planes all feature an adjustable mouth that can be closed to a narrow slit for fine shavings with minimum tear-out or opened for heavier cuts. All of this can be done quickly and accurately with the toe locking knob and the unique mouth adjustment screw. The blades are lapped and are available in either A2 tool steel hardened to Rc60-62 or O1 tool steel hardened to Rc58-60.

Each plane body is fully stress-relieved, ductile cast iron. It is accurately machined and ground so that the sole is flat and the sides are square to the sole. The large wooden front knob and rear handle provide a comfortable grip. The adjustment mechanism, with its combined feed and lateral adjustment knob, makes blade setting easy and accurate. The set screws on either side of the blade prevent it from shifting in use, but allow full lateral adjustment.

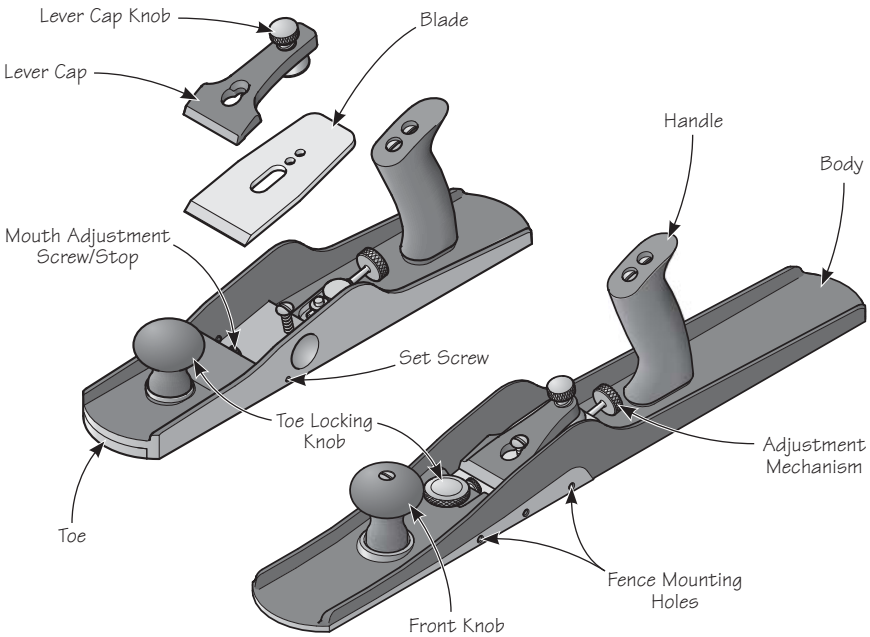

**Figure 1: Plane components.**

## Blade Adjustment



**Caution:** Be aware that the blade is sharp; careless handling can result in serious injury.

To initially set the blade, open the mouth fully and place the plane on a flat wood surface (e.g., a scrap of stock). Lightly clamp the blade with the lever cap knob and advance the blade until it just touches the wood.

Flip the plane to a sole-up position, then sight along the sole to ensure the blade edge is parallel to the sole and advance or retract it as required. Clamp fully ( $1/4$  turn should be ample – **do not overclamp**) and take a test cut. If all is well, advance the set screws on either side until they just touch the blade, not to clamp it but to create a guide so that you do not have to be concerned about the blade shifting sideways at the front. All lateral adjustment will now be governed solely by movement of the adjustment mechanism. This is a substantial advance over all other designs, which either have a milled slot at the front and no lateral adjust, requiring you to sharpen your blade to exactly  $90^\circ$  to the blade side, or have room for the blade to shift sideways at the tip every time you want to change your depth of cut.

You will quickly get accustomed to setting blade depth by sighting along the sole, but for setting very fine shavings, you will still need to take test cuts.

### **Two Cautionary Notes:**

1. *The lever cap knob has tremendous mechanical advantage. For normal use, it needs to be tightened only  $1/4$  turn after full engagement with the blade. **Never torque it down as hard as you can or you may damage the plane.***
2. *Before advancing the blade at any time, check the mouth opening to be sure you don't run the blade against the adjustable toe piece. It is a simple matter to close the mouth to the desired opening **after** you have reached the right blade projection. Better to dull the blade in use than when adjusting it.*

## Backlash and How to Avoid It

To eliminate the possibility of the blade shifting backward unpredictably as the backlash is taken up, the final setting should always be made with the blade being advanced by the clockwise movement of the thumbscrew. If you need to retract the blade slightly, retract it more than required, and finish by **advancing** it to its desired position. This takes up all the play in the forward direction, resisting the backward forces experienced by the blade.

# Mouth Adjustment

The movable toe piece enables you to set the gap between the blade and the toe piece (this opening is called the mouth) to suit the task. Generally, you will want a mouth as small as will allow the shaving to escape. The reason for this is that a tight mouth supports the wood ahead of the blade, preventing break-out, a shaving propagating below the surface of the workpiece.

The mouth adjustment screw/stop allows you to accurately set this opening and, once set, ensures that you cannot inadvertently slide the toe backwards so that it contacts, and possibly damages, the blade. Loosen the toe locking knob and, holding the plane vertical, adjust the position of the toe by turning the mouth adjustment screw/stop in or out as required. When the desired mouth opening is achieved, tighten the toe locking knob firmly, but avoid overtightening.

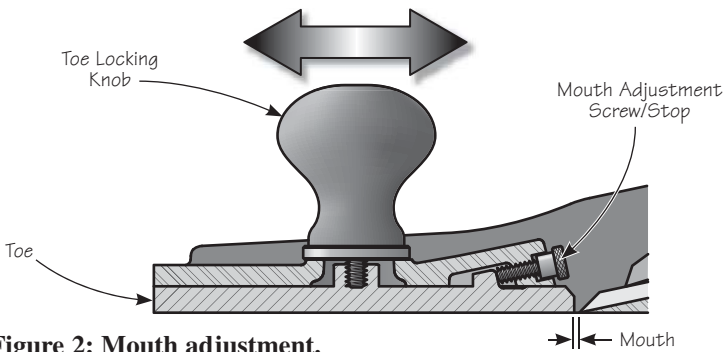

Figure 2: Mouth adjustment.

# Blade Sharpening

The 25° bevel blade is ideal for fine trimming work on end-grain softwood and some hardwoods. Ring-porous hardwoods such as oak may require a 30° bevel to prevent blade edge failure. Simply hone the micro-bevel to the required angle.

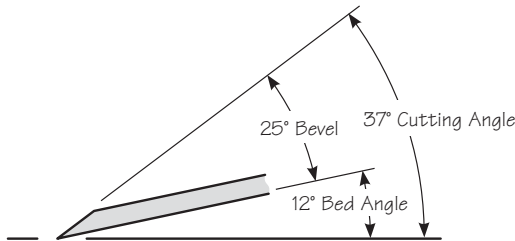

Figure 3: 25° blade geometry.

It is difficult to be definitive about bevel angles. Some people never skew a plane in use; other people always skew it. If you normally use a plane in a skewed position, you can get away with lower bevel angles. If you are always working clear pine, you can get away with very low bevel angles. Only you know which wood you will be working and how you will be working it. Experience will tell you what you can and cannot do.

# High-Angle Smoothing

The optional high-angle blades enable a bevel-up plane to excel at smoothing woods with varying grain.

The 38° blade yields an effective cutting angle of 50° (commonly known as a York pitch) and is an excellent blade for general smoothing. Higher cutting angles require greater force to push the plane, making the 38° bevel the ideal starting point (a balance of performance and effort) when working difficult wood.

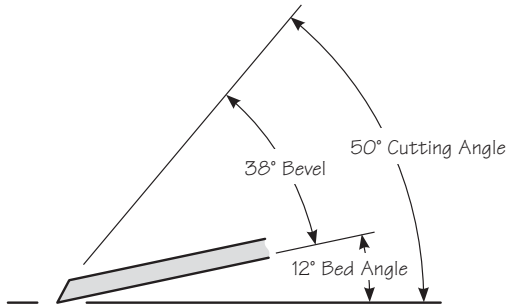

**Figure 4: 38° blade geometry.**

The 50° blade is for smoothing woods with widely varying or reversing grain (e.g., bird's-eye maple) where tear-out is difficult to control. The resulting cutting angle of 62° produces what is known as a Type II chip (or shaving), one created by wood failure right at the cutting edge, eliminating tear-out on even the most difficult grain patterns. Planing wood at this cutting angle will give you a bit of a workout – but the results are well worth it.

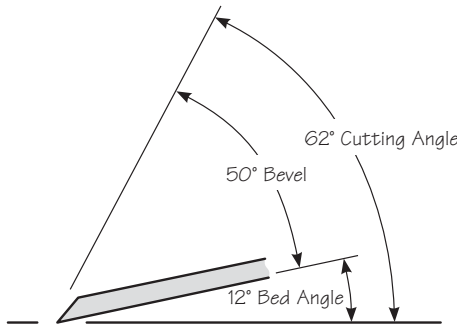

**Figure 5: 50° blade geometry.**

***Note:** You can convert a 25° blade to a high-angle blade by simply changing the micro-bevel; however, changing back to 25° requires substantially more work due to the amount of blade material that must be removed. If you plan on using this plane for various applications, having multiple blades with different bevel angles gives you the option of quickly changing the cutting angle without having to rework the blade.*

You can sharpen the blade as you would any other blade; however, a honing guide will greatly ease the task of accurately setting primary and micro-bevel angles.

## Reference

For additional information about blade sharpening, a number of excellent references are available, such as *The Complete Guide to Sharpening* by Leonard Lee, Taunton Press of Newtown, CT.

## Cutting End Grain

The low  $12^\circ$  bed angle together with a  $25^\circ$  bevel on the blade results in an effective cutting angle of  $37^\circ$ , which is ideal for end-grain work. Cutting end grain differs from planing with the grain; it calls for a lot of pressure and control. In fact, cutting end grain requires nearly three times the force that it takes to cut parallel to the grain. You can do four things to make end-grain cutting easier. First, keep the edge of the blade as keen as possible. Second, take lighter cuts. Third, keep the bevel angle of the blade as low as possible and consistent with edge retention; however, this is a matter of trial and error. You start with a low bevel angle and increase it only if you get edge failure. The failure is quickly evident by scratches showing up on the end grain. Fourth, skew the plane. Instead of cutting directly across the grain, hold the plane askew to the path of travel. This has exactly the same effect as lowering the bevel angle, because it lowers the cutting angle. If you have a  $37^\circ$  cutting angle, by rotating the plane  $45^\circ$  and taking a skew cut, you will get the same cutting action that you would if you had lowered the bevel angle to  $28^\circ$ . If you skewed the plane even more, say to  $60^\circ$ , you would get a cutting angle of  $21^\circ$ . The edge does not fail because exactly the same amount of distortional force is being applied over greater blade width. This leads directly to one of the little-known facts about tool technique – a blade used at a skew can be sharpened at a lower angle than a blade used to cut squarely across the wood, and the skewed blade will still retain its edge.

Planing end grain involves a lot of force. It is therefore important to have the workpiece firmly clamped in position. If possible, clamp the workpiece upright in a vise, keeping it low so that it will be secure and comfortable to work. You can prevent the edge of the workpiece from splitting when planing end grain by clamping a small scrap block to the edge.

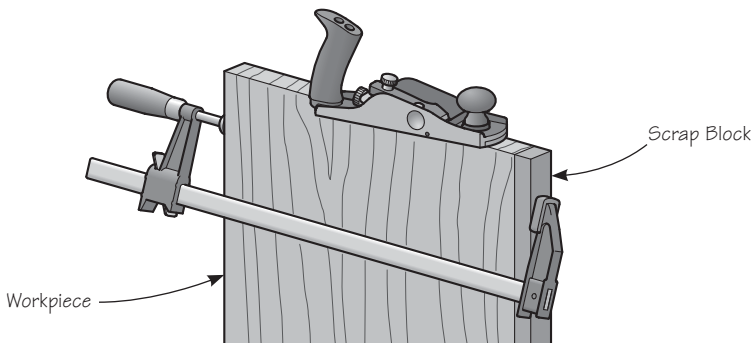

**Figure 6: Preventing splitting.**

## Care and Maintenance

The body of our bevel-up planes is ductile cast iron and comes treated with rust preventative. Remove this using a rag dampened with mineral spirits. Clean all machined surfaces, including the area under the nose and the toe itself.

We recommend that you initially, then periodically, apply a light coat of paste wax to seal out moisture and prevent rusting; this also has the added bonus of acting as a lubricant for smoother planing. Wipe off any wood dust from the surfaces that you will be waxing, apply a light wax coating, let dry, then buff with a clean soft cloth. At the same time, the solvents in the wax will remove any harmful oils left from your fingers that can lead to corrosion. This is especially important with planes that are gripped on the machined surfaces, such as when using this plane for shooting.

Keep in mind that paste wax contains silicone that, if transferred to your workpiece, could cause finishing problems such as "fish eyes". To avoid this problem, use silicone-free products, such as Waxilit® sliding agent and glue release, or a tool surface sealant. Either is an excellent alternative to regular paste wax. However, before treating a plane with a sealant, wipe off any fingerprints with a cloth dampened with a small amount of light machine oil. Remove any residual oil; then apply the sealant to the plane's sole and cheeks.

If storage conditions are damp or humid, the plane should, in addition to the treatment outlined above, be wrapped in a cloth or stored in a plane sack. This precaution will also guard against dings and scratches.

Every so often, take the plane apart to clean and lubricate it where necessary. Remove the lever cap, blade, adjustment mechanism and toe from the body. Clean all parts with a cloth dampened with a dab of light machine oil. The blade bed and machined contact surfaces between the body and toe, as well as the adjustment components (pivot, threaded shaft and traveller), will benefit from a light coat of oil to keep them working freely. For corroded plane bodies, we recommend you first remove the rust with a fine rust eraser, then treat as described above.

The bright finish on the brass components can be maintained as above. If a patina finish is preferred, simply leave the brass components unprotected until the desired level of oxidation has occurred, then apply a sealant. If you want to make them bright and shiny again, you can revitalize the surface with a brass polish.

The rosewood knob and handle have a lacquer finish and should require nothing more than a wipe with a clean cloth from time to time.

# Accessories

| 0.125" x 1 <sup>3</sup> / <sub>4</sub> " | 0.125" x 2"     | 0.187" x 2 <sup>1</sup> / <sub>4</sub> " | Description          |
|--|-----------------|--|----------------------|
| <b>05P39.02</b>                          | <b>05P25.02</b> | <b>05P34.02</b>                          | 25° A2 Blade         |
| <b>05P39.03</b>                          | <b>05P25.03</b> | <b>05P34.03</b>                          | 38° A2 Blade         |
| <b>05P39.04</b>                          | <b>05P25.04</b> | <b>05P34.04</b>                          | 50° A2 Blade         |
| <b>05P39.06</b>                          | <b>05P25.06</b> | <b>05P34.06</b>                          | 38° A2 Toothed Blade |
| <b>05P39.52</b>                          | <b>05P25.52</b> | <b>05P34.52</b>                          | 25° O1 Blade         |
| <b>05P39.53</b>                          | <b>05P25.53</b> | <b>05P34.53</b>                          | 38° O1 Blade         |
| <b>05P39.54</b>                          | <b>05P25.54</b> | <b>05P34.54</b>                          | 50° O1 Blade         |

**05P37.05** Bevel-Up Jointer Fence

---

**veritas**<sup>®</sup> Tools Inc.

814 Proctor Avenue      1090 Morrison Drive  
 Ogdensburg NY 13669-2205      Ottawa ON K2H 1C2  
 United States      Canada